



The nozzle types listed in this chapter cover a wide range of uses. The modular nozzle design allows a rapid replacement of components when required. The two-component shaft (patented) with varying design features assures excellent insulation in the front area of the shaft and the least possible loss of heat between the hot runner nozzle and the cavity.

Where requirements are high in terms of appearance, reduced cycle times, minimum shear stress and large gate cross-sections, **valve-gate technology** provides the solution.

The single nozzles are operated pneumatically (max. of 8 bar). The cylinders are mounted externally. The new innovative design of the contouring needle guide and the optimised valve-gate needle allow non-contact and low-wear gate closing. The PM needle guide made of metallurgical powder steel ensures economical and virtually wear-free operation. While closing, the needle is first centered through a tapered guide until it lowers precisely into the cylindrical guide.

Another advantage is the separation of needle guide and material tube, which means that any necessary change of needle guide is a simple procedure.

NEW

"Electromagnet ME 10/UV75", electric drive for valve-gate systems, chapter 4.
 • for electric injection moulding machine
 • absolute clean room compatible

Technical data	
Type	Valve-gate nozzle with exchangeable needle guide. Used as a single nozzle or in combination with 230 V manifolds.
Heating element	Pressed-in 230 V heating elements. Power from 80 W to 650 W is depending on size and length, easy to exchange.
Material tube-ø	From ø3.8 mm to ø12 mm, depending on nozzle type.
Needle guide	Valve-gate nozzles are equipped with a wear-resistant needle guide made of PM steel. This can be replaced when necessary.
Nozzle shaft	ø14 mm to ø38 mm (depending on size) Flat nozzle 4NFT nozzle shaft W1 10 mm / 22 mm 5NFT nozzle shaft W1 14 mm / 26 mm 6NFT nozzle shaft W1 14 mm / 26 mm
Nozzle length	From 40 mm to 350 mm, depending on nozzle type. >350 mm on request.
Thermocouple	Measuring point at the gate.
Thermo connection	Fixed or pluggable with flexible cable.
Power receptacle	Fixed or pluggable with flexible cable.
Pitch center	Starting at 14.5 mm (nozzle is reduced to size "W"), <14.5 on request.
Part weight	From 0.2 g to 5000 g depending on type of processing material.
Line pressure	Single valve-gate nozzle Pneumatic actuation: Depending on the system, pressures of up to 10 bar (min. 8 bar) may be necessary. System max. admissible 2000 bar
Control	Single zone control: DP1 / 2 Multi zone control: DP3 / 5, DPT5 - 15, DPT20 - 45 DPT multizone

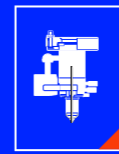

T = Voltage 230 Volt

Only for single nozzle/ pneumatic
 S = Steel piston ring

E = Single nozzle, with shaft/ without shaft
 F = Nozzle for limited tool space
 H = Nozzle with shaft
 L = Nozzle for limited tool space, without shaft
 M = Nozzle for limited tool space, with shaft
 N = Nozzle for limited tool space, without shaft
 T = Nozzle screwed from parting line, with shaft

N = Valve-gate nozzle

ød = Material tube ø

Order code: 5 N E S T 50 L A LA S

L = Nozzle length

Actuation medium single nozzle
 L = Pneumatic

Plug position single nozzle
 A = } Position of power and thermo connections
 B = }

LA = } PM needle guide
 LAZ = }

S = Special design

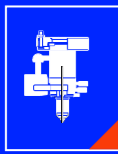

- Heat expansion gap "K"
The "K" dimension required for the heat expansion must be ensured by grinding the titanium ring (5 mm)! The heat expansion gap is calculated by determining the difference between the nozzle (position of the titanium ring in the head of the nozzle) and the height of the mould (position of the centring ring) when assembled.
*Δ T specifies the difference between the processing temperature and the mould temperature!

Nozzle type NEST

Typ	ΔT(°C)*	100	150	200	250	300	350
5-6-8	K (mm)	0.09	0.16	0.23	0.29	0.36	0.42
10-12	K (mm)	0.11	0.19	0.26	0.33	0.41	0.48

The "K" dimensions allow for 0.03 mm pretensioning!

- Recess for the M5 screws of the nozzle head.
- Power and thermo connection may be bent only **once** in this area. Minimum bending radius R8.
- The cable channel layout is determined by the pitch center and location.
- Dimension L ^{+0.02} is dependent on the gate diameter.
- If the valve gate nozzle is fitted with the nominal length, the needle projects 0.5 mm into the part.

Please note

- Positive sealing
There is no positive sealing between the nozzles and the manifold when the hot runner system is cold. The system is sealed when the operating temperature is reached.
- Hot runner nozzle
 - In case of limited installation dimensions, the nozzle head can be flattened to fit the dimension W when using the following nozzle types: NHT/NLT/NMT/NTT
 - The nozzle type NMT/NTT/NTT hot runner nozzles are not screwed to the manifold .
 - Take care with the metal o-rings when assembling; they provide sealing when warm. The metal o-rings are to be fixed in position in the groove with some grease.
 - Titanium ring and metal o-ring are included in delivery. Spare parts, chapter 7.
 - After every disassembly a new metal o-ring must be inserted when refitting the nozzle, chapter 7.**
 - Disassemble the nozzle out of the cavity plate please use a nozzle extractor tool, chapter 7.
- Gate diameter
The gate diameter D depends on the material used, part weight and nozzle diameter.
- Pitch center
 - The minimum pitch center depends on the nozzle type. If the nozzle heads are close together than a support piece **is not** necessary.
 - Please note the dimensions of the needle actuation.
- High temperature application
Please call our technical consulting if you have questions about high temperature applications **>320°C**.
- Dimensions and tolerances
Dimensions and tolerances given refer to the mold.
- Heat expansion gap "K"
Please see chapter 3 (yellow page) for the heat expansion gap dimension "K".

8. Maximum tightening torque

Threads	Property class	
	10.9	12.9
M4	3.8 Nm	4.6 Nm
M5	8 Nm	9.5 Nm
M6	13 Nm	16.0 Nm
M8	32 Nm	39.0 Nm
M10	64 Nm	77.0 Nm
M12	110 Nm	135.0 Nm

9. Technical information, chapter 1.4.

Tolerance zone for the nozzle seat in the cavity plate:

Dimensions \varnothing H7	> 10...18 =	+0,018 0
	> 18...30 =	+0,021 0
	> 30...50 =	+0,025 0
	> 50...80 =	+0,030 0
	> 120...180 =	+0,040 0
Dimensions \varnothing H8	> 30...50 =	+0,039 0
	> 50...80 =	+0,046 0

- NEST Single valve-gate nozzle
Caution! When assembling / dismantling the needle holder (A/F 10), care must be taken not to deform the steel piston rings. Use the flat of the piston!
It is essential to put the metal o-ring back in after replacing the disk package.
The piston and/or the steel piston rings must be greased again before assembly (GÜNTHER recommends Klüber paste UH 196-402 [NSF registered]).
- Inlet/ outlet pipes for activating the needle
It is preferable to use channels with diameters of 6 mm and a minimum length of 200 mm. The inlet and outlet lines must be placed in the cooled mould plate in order to prevent the medium overheating.
If the mould temperatures exceed the thermal stress capability of the pneumatic valves, a separately cooled manifold must be installed. The mechanics of the needle drive and the valve-gate nozzle are absolutely capable of withstanding high temperatures.

Order code

Following parts must be ordered separately:

Please note that plugs and receptacles for NEST nozzles are to be ordered double, chapter 6.

- CMLK thermoplug for nozzle type NEST, NHT, NLT, NTT
- CMT power receptacle for nozzle type NEST, NHT, NLT
- FKT power receptacle for nozzle type NTT
- The needle **is not** a component of the valve-gate nozzle because the needle length depends on the nozzle length, actuation mechanism and manifold assembly.
- The PM needle guide **is not** a component of the valve-gate nozzle.

If you have any questions please call our technical consulting at +49 (0) 6451 - 50 08 0.

PM needle guide LA
Cut-out in the gate area

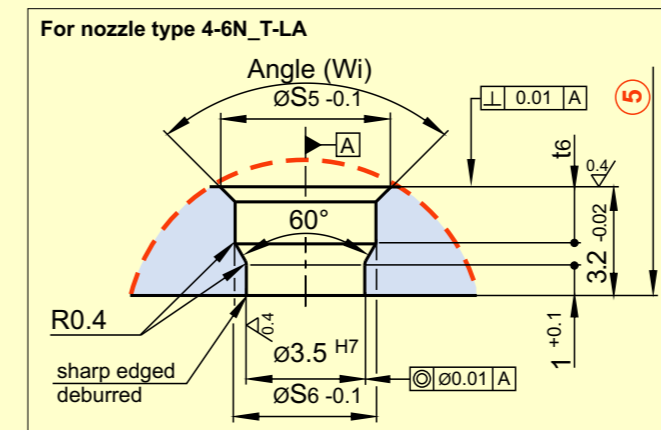

Nozzle type	ØS5	ØS6	t6	Angle (Wi)
4N_T-LA	4.1	3.9	1.85	60°
5N_T-LA	5.0	4.6	1.25	90°
6N_T-LA	5.0	4.6	1.25	90°

For the nozzle type 8-12N_T-LA

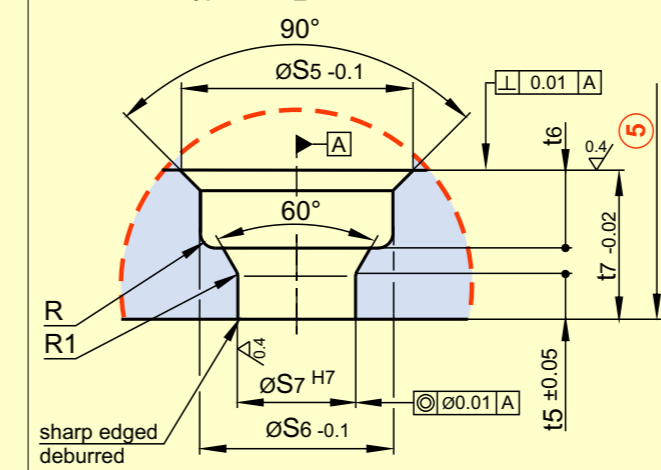

Nozzle type	R	R1	ØS5	ØS6	ØS7	t5	t6	t7
8N_T-LA	0.4	0.4	7.4	7.0	5.0	1.20	2.2	4.2
10N_T-LA	0.8	1.2	10.8	10.4	6.5	1.32	2.6	4.8
12N_T-LA	0.8	1.2	10.8	10.4	6.5	1.32	2.6	4.8

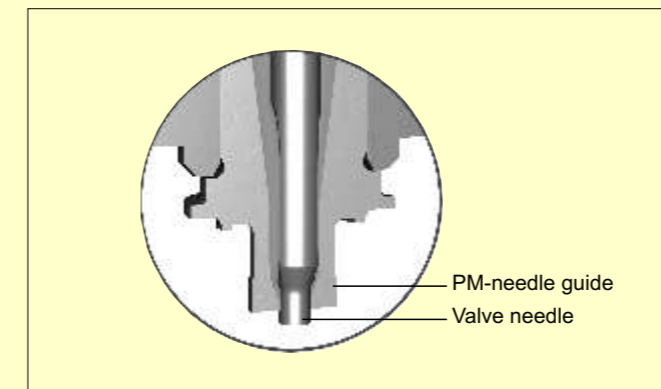

7 PM needle guide LA
of metallurgical powder steel

The needle guide can be easily changed as required. By replacing the PM needle guide and the needle, the injection gate diameter can be enlarged or reduced without any re-machining of the mold nest. The precision of the needle guide allows a virtually wear-free seal and a clean gate without burrs.

Advantages:

- High longevity due to extreme wear resistance
- Insert exchangeable
- Short cycle times
- Excellent and vestige-free gating quality
- Very good cosmetic quality
- No need to replace or re-machine mold inserts
- Low shear stress

For more technical information please see the respective nozzle type page.

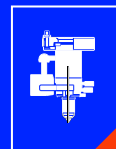

PM needle guide

PM needle guide LA Special design with titanium ring Cut-out in the gate area

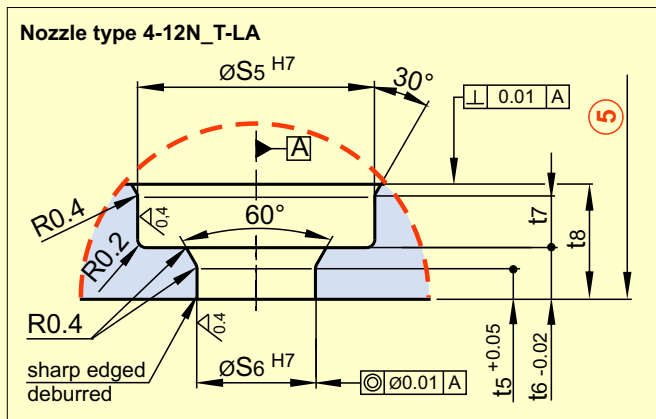

Nozzle type	$\varnothing S_5$	$\varnothing S_6$	t_5	t_6	t_7	t_8
4N_T-LA	6.5	3.5	1.00	1.4	1.4	3.2
5N_T-LA	7.0	3.5	1.00	1.4	1.5	3.2
6N_T-LA	7.0	3.5	1.00	1.4	1.5	3.2
8N_T-LA	10.0	5.0	1.20	2.4	1.5	4.2
10N_T-LA	14.5	6.5	1.32	2.2	2.2	4.8
12N_T-LA	14.5	6.5	1.32	2.2	2.2	4.8

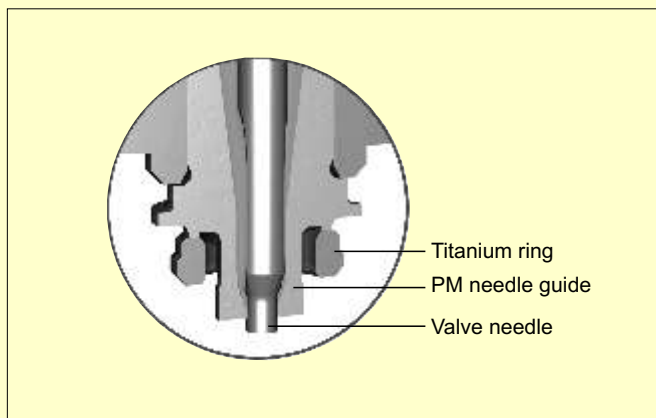

7 PM needle guide LA

Special design with titanium ring

The thermal insulation of the PM needle guide provided by a titanium ring allows a much wider range of applications of the valve gate nozzle with the following plastics

- Polyamides (PA46, PA66, HTN)
- Thermoplastic polyesters (PBT, PET)
- Liquid crystalline polymer (LCP)
- Polyetheretherketone (PEEK)

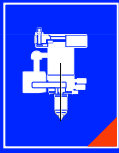

PM needle guide LAZ Cut-out in the gate area

⑦ PM needle guide LAZ of pulvermetalurgical steel

The needle guide can be easily changed as required. By replacing the PM needle guide and the needle, the injection gate diameter can be enlarged or reduced without any re-machining of the mold nest. The precision of the needle guide allows a virtually wear-free seal and a clean gate without burrs.

The LAZ needle guide is tapered in form with a smaller contact area, which reduces the imprint made. This version is suitable for molding parts with a small wall thickness, or for parts which contours do not permit any larger imprint.

Advantages:

- High longevity due to extreme wear resistance
- Insert exchangeable
- Short cycle times
- Excellent and vestige-free gating quality
- Very good cosmetic quality
- No need to replace or re-machine mold inserts
- Low shear stress

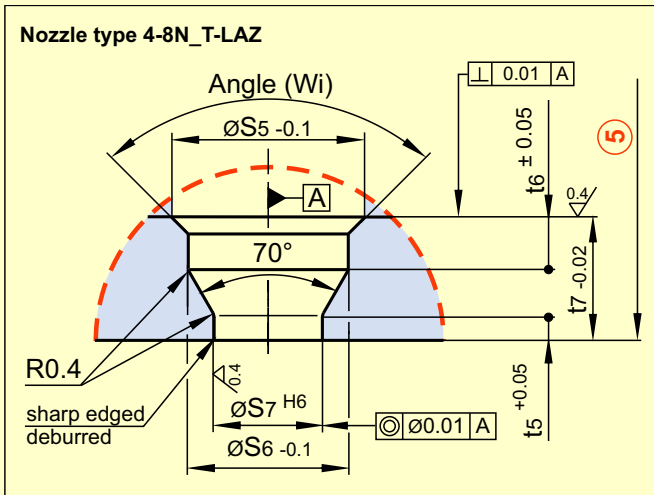





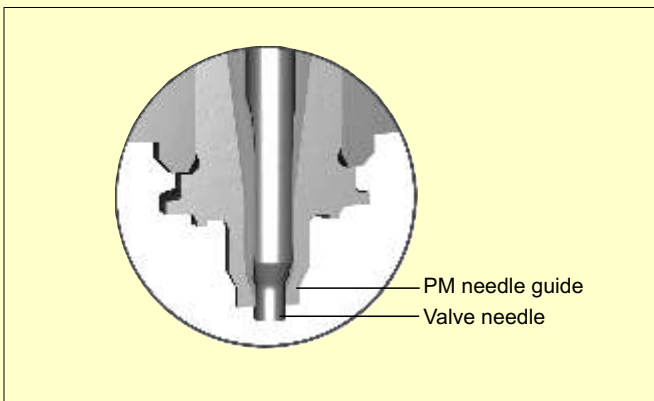

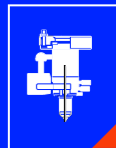
Nozzle type	ØS5	ØS6	t5	t7	Angle (Wi)
4N_T-LAZ	4.1	3.9	0.58	3.2	60°
5N_T-LAZ	5.0	4.6	0.58	3.2	90°
6N_T-LAZ	5.0	4.6	0.58	3.2	90°
8N_T-LAZ	7.4	7.0	0.63	4.2	90°

		4N_T-LAZ	5N_T-LAZ	6N_T-LAZ	8N_T-LAZ
ØD	ØS7	t6	t6	t6	t6
0.8	2.2	1.41	0.91	0.91	-
1.0	2.4	1.55	1.05	1.05	-
1.2	2.6	1.70	1.20	1.20	-
1.4	2.8	1.84	1.34	1.34	-
1.6	3.0	-	-	1.48	-
2.0	3.5	-	-	-	1.07
2.5	4.0	-	-	-	1.43



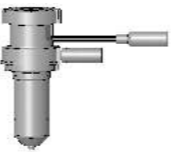

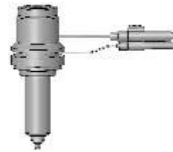
Nozzle / material compatibility

Nozzle type		NEST, pneumatic					NFT			NHT					NLT						NMT						NNT			NTT							
																																					
		Page 2.3. 20, 22, 24					Page 2.3. 40			Page 2.3. 60					Page 2.3. 80						Page 2.3. 100						Page 2.3. 120			Page 2.3.140							
Nozzle-ø		5	6	8	10	12	4	5	6	4	5	6	8	10	12	4	5	6	8	10	12	4	5	6	8	10	12	4	5	6	4	5	6	8	10	12	
ABS		■	■	■	■	■	■	■	■	■	■	■	■	■	■	■	■	■	■	■	■	■	■	■	■	■	■	■	■	■	■	■	■	■	■	■	
LCP**		■	■	■	■	■	■	■	■	■	■	■	■	■	■	■	■	■	■	■	■	■	■	■	■	■	■	■	■	■	■	■	■	■	■	■	
PA 4.6		■	■	■	■	■	■	■	■	■	■	■	■	■	■	■	■	■	■	■	■	■	■	■	■	■	■	■	■	■	■	■	■	■	■	■	
PA 6		■	■	■	■	■	■	■	■	■	■	■	■	■	■	■	■	■	■	■	■	■	■	■	■	■	■	■	■	■	■	■	■	■	■	■	
PA 6+V0+W*		■	■	■	■	■	■	■	■	■	■	■	■	■	■	■	■	■	■	■	■	■	■	■	■	■	■	■	■	■	■	■	■	■	■	■	
PA 6.6		■	■	■	■	■	■	■	■	■	■	■	■	■	■	■	■	■	■	■	■	■	■	■	■	■	■	■	■	■	■	■	■	■	■	■	
PA 6.6+V0+GF		■	■	■	■	■	■	■	■	■	■	■	■	■	■	■	■	■	■	■	■	■	■	■	■	■	■	■	■	■	■	■	■	■	■	■	
PA 6.6+V0+W*		■	■	■	■	■	■	■	■	■	■	■	■	■	■	■	■	■	■	■	■	■	■	■	■	■	■	■	■	■	■	■	■	■	■	■	
PA 11		■	■	■	■	■	■	■	■	■	■	■	■	■	■	■	■	■	■	■	■	■	■	■	■	■	■	■	■	■	■	■	■	■	■	■	
PA 12		■	■	■	■	■	■	■	■	■	■	■	■	■	■	■	■	■	■	■	■	■	■	■	■	■	■	■	■	■	■	■	■	■	■	■	
PBT		■	■	■	■	■	■	■	■	■	■	■	■	■	■	■	■	■	■	■	■	■	■	■	■	■	■	■	■	■	■	■	■	■	■	■	
PBT+V0		■	■	■	■	■	■	■	■	■	■	■	■	■	■	■	■	■	■	■	■	■	■	■	■	■	■	■	■	■	■	■	■	■	■	■	■
PBT+V0+W*		■	■	■	■	■	■	■	■	■	■	■	■	■	■	■	■	■	■	■	■	■	■	■	■	■	■	■	■	■	■	■	■	■	■	■	■
PC		■	■	■	■	■	■	■	■	■	■	■	■	■	■	■	■	■	■	■	■	■	■	■	■	■	■	■	■	■	■	■	■	■	■	■	■
PE		■	■	■	■	■	■	■	■	■	■	■	■	■	■	■	■	■	■	■	■	■	■	■	■	■	■	■	■	■	■	■	■	■	■	■	■
PEEK**		■	■	■	■	■	■	■	■	■	■	■	■	■	■	■	■	■	■	■	■	■	■	■	■	■	■	■	■	■	■	■	■	■	■	■	■
PET		■	■	■	■	■	■	■	■	■	■	■	■	■	■	■	■	■	■	■	■	■	■	■	■	■	■	■	■	■	■	■	■	■	■	■	■
PMMA		■	■	■	■	■	■	■	■	■	■	■	■	■	■	■	■	■	■	■	■	■	■	■	■	■	■	■	■	■	■	■	■	■	■	■	■
POM copolimer		■	■	■	■	■	■	■	■	■	■	■	■	■	■	■	■	■	■	■	■	■	■	■	■	■	■	■	■	■	■	■	■	■	■	■	■
PP		■	■	■	■	■	■	■	■	■	■	■	■	■	■	■	■	■	■	■	■	■	■	■	■	■	■	■	■	■	■	■	■	■	■	■	■
PPS**		■	■	■	■	■	■	■	■	■	■	■	■	■	■	■	■	■	■	■	■	■	■	■	■	■	■	■	■	■	■	■	■	■	■	■	■
PS		■	■	■	■	■	■	■	■	■	■	■	■	■	■	■	■	■	■	■	■	■	■	■	■	■	■	■	■	■	■	■	■	■	■	■	■
PVC, soft		■	■	■	■	■	■	■	■	■	■	■	■	■	■	■	■	■	■	■	■	■	■	■	■	■	■	■	■	■	■	■	■	■	■	■	■
PVC, hard		■	■	■	■	■	■	■	■	■	■	■	■	■	■	■	■	■	■	■	■	■	■	■	■	■	■	■	■	■	■	■	■	■	■	■	■
SAN		■	■	■	■	■	■	■	■	■	■	■	■	■	■	■	■	■	■	■	■	■	■	■	■	■	■	■	■	■	■	■	■	■	■	■	■
TPE		■	■	■	■	■	■	■	■	■	■	■	■	■	■	■	■	■	■	■	■	■	■	■	■	■	■	■	■	■	■	■	■	■	■	■	■
TPU		■	■	■	■	■	■	■	■	■	■	■	■	■	■	■	■	■	■	■	■	■	■	■	■	■	■	■	■	■	■	■	■	■	■	■	■

- Suitable
- Limited suitability
- On request

* Heat stabilized, please contact us
 ** Only nozzles for high temperature applications, no standard version

Nozzle type

- E = single nozzle with shaft/ without shaft
- F = for extremely limited tool space, screwed to the manifold
- H = screwed to the manifold with shaft
- L = screwed to the manifold, without shaft

- M = for limited tool space, not screwed to the Manifold, with shaft
- N = for limited tool space, not screwed to the manifold, without shaft
- T = screwed from parting line, with shaft

The nozzle size depends on the shot weight, taking into consideration pressure drop and dwell time.
 To confirm material/nozzle compatibility please contact our technical consulting department.

Valve-gate nozzle type NMT

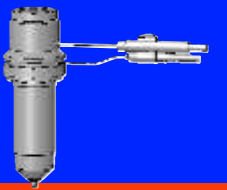

Assembly

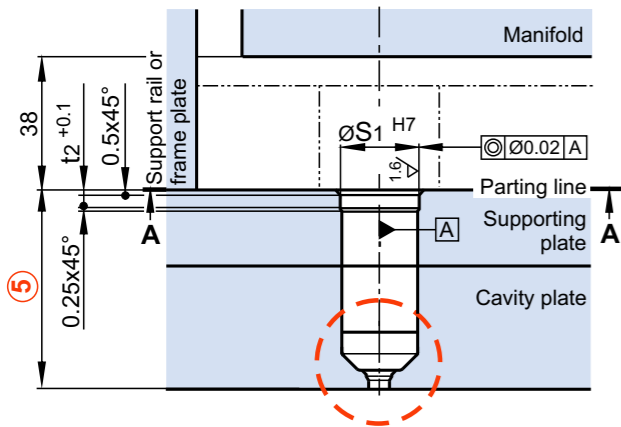

4-6NMT View A-A: Recess in the frame plate

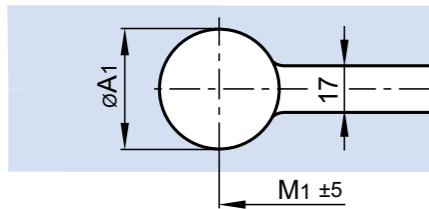

8-12NMT View A-A: Recess in the frame plate

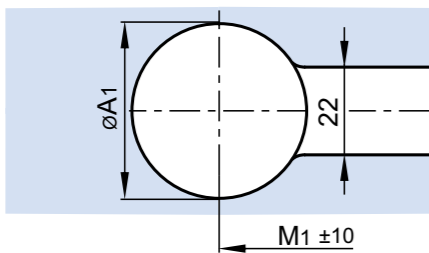

Dimensions

Nozzle type NMT	Nozzle (mm)								Assembly (mm)					
	$\varnothing A$	$\varnothing B$	$\varnothing d$	M	q_1	$\varnothing S$	$\varnothing S_1$	W	$\varnothing A_1$	M_1	$\varnothing S_2$	t_1	t_2	V
4	29.0	24.5	3.8	72	-	20	21	22.5	33	92	20.5	30	5	9.2
5	33.0	26.5	4.8	88	-	22	23	23.5	37	108	22.5	32	5	9.0
6	33.6	27.4	6.0	88	-	26	27	27.5	38	108	26.5	35	5	11.0
8	50.0	36.0	7.5	115	13	26	27	38.0	54	135	26.5	35	5	11.0
10	58.0	39.0	10.0	115	14	32	33	46.0	62	135	32.5	38	10	13.9
12	58.0	39.0	12.0	115	14	38	39	46.0	62	135	38.5	39	10	15.3

Order code

Example: 4NMT50 Valve-gate nozzle

- Material tube- \varnothing 3.8 mm,
- Valve-gate nozzle, connected with the manifold,
- Length 50 mm

Please indicate the gate \varnothing and needle guide in your order.

Notes

- ③ ... as well as further technical notes on the "yellow page".



Valve-gate nozzle for limited tool space, not screwed to the manifold, with shaft

4-6NMT

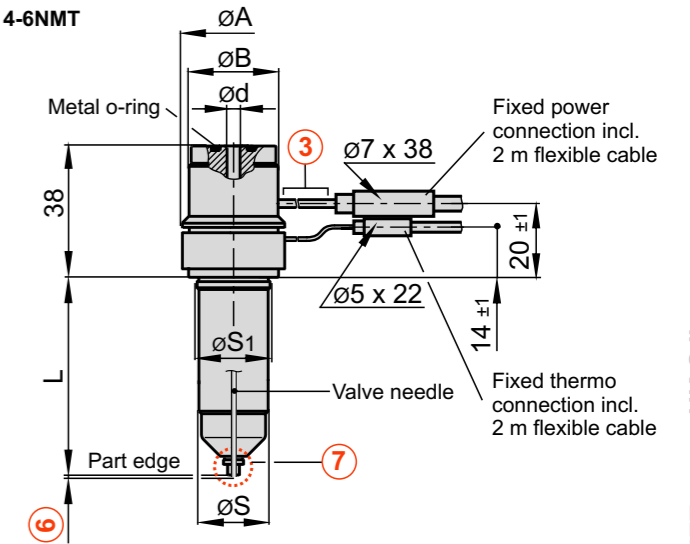

8-12NMT

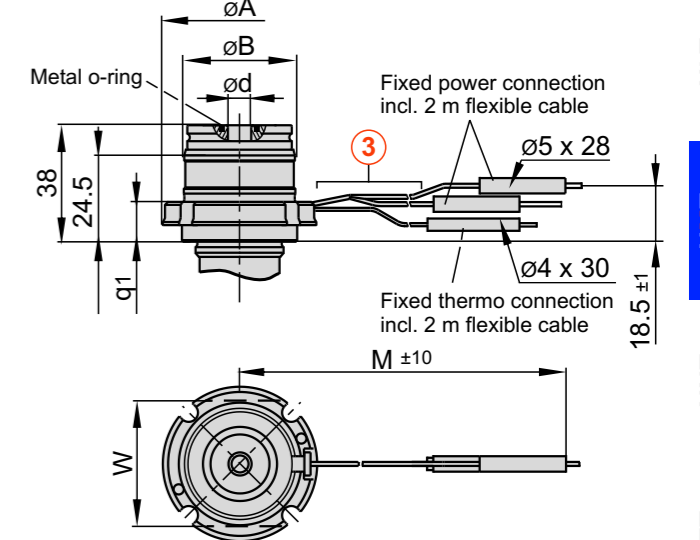

Delivery time

Nozzle type NMT	Nozzle length L (mm)										
	40	50	60	80	100	120	150	200	250	300	350
4	○	●	●	●	●	●	●	●	●	●	●
5	●	●	●	●	●	●	○	○	○	○	○
6	●	●	●	●	●	●	○	○	○	○	○
8	●	●	●	●	●	●	●	●	●	●	●
10	●	●	●	●	●	●	●	●	●	●	●
12	●	●	●	●	●	●	●	●	●	●	●

● = in stock, ● = short delivery time, ○ = delivery time upon request